

# Leonardo

Divani componibili | *Modular seating systems*

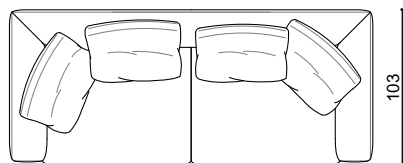
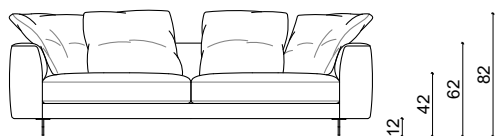
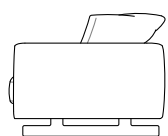

**Rivestimenti:** Tessuto - Pelle - Cuciture tono su tono.

**Struttura:** Telaio composto da multistrato, legno e derivati (classe E1).

Molleggio con cinghie elastiche ad alta resistenza.

**Bracciolo:** Poliuretano espanso ad alta portanza e densità variabile rivestito in piuma sterilizzata e fibra poliestere.

**Seduta:** Poliuretano espanso sagomato a densità differenziate rivestito in fibra poliestere.

**Schienali:** Piuma sterilizzata e fibra poliestere.

**Piedi:** Metallo finitura Carbonio Lucido o Bronzo.

**Upholstery:** Fabric - Leather - Tone on tone stitching.

Structure: Plywood, wood and derivatives (class E1). Suspension with high resistance elastic belts.

**Armrest:** Polyurethane foam with high support and variable density covered with sterilized feather and polyester fibre.

**Seat:** Moulded polyurethane foam with variable densities covered with polyester fibre

**Backrest:** Sterilized feather and polyester fibre.

**Feet:** Metal in glossy Carbon or Bronze finish.

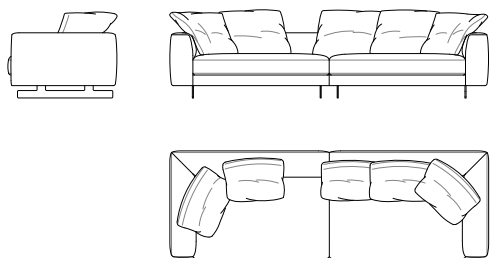

**360**  
L 310 x P 103 x H 82 cm

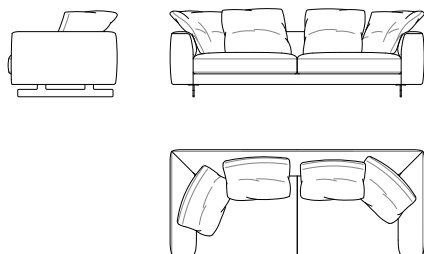

**350**  
L 240 x P 103 x H 82 cm

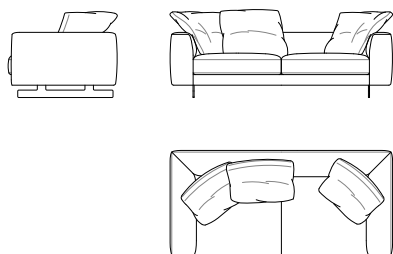

**300**  
L 210 x P 103 x H 82 cm

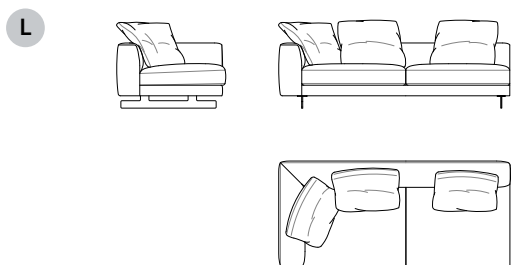

**380 - 370**  
L 218 x P 103 x H 82 cm

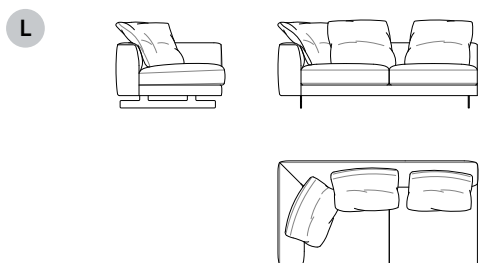
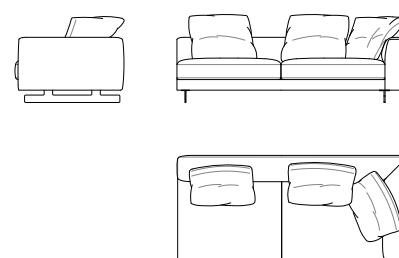

**330 - 320**  
L 188 x P 103 x H 82 cm

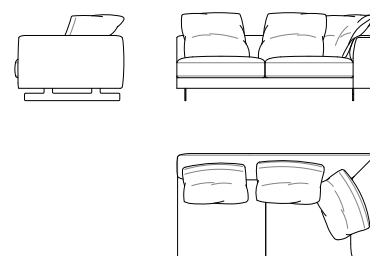

L

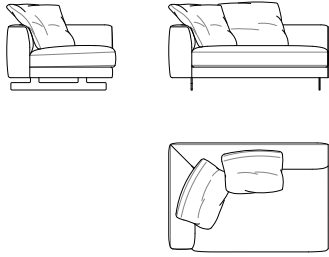

**230 - 220**

L 150 x P 103 x H 82 cm

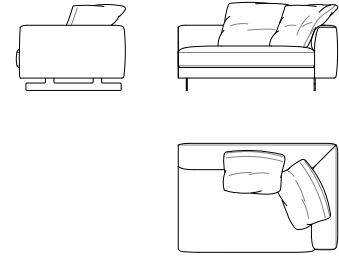

R

L

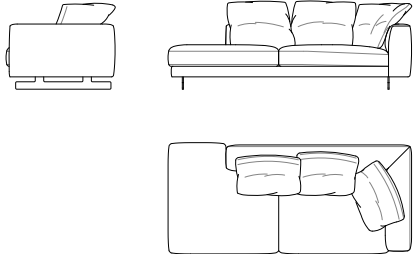

**670 - 660**

L 230 x P 105 x H 82 cm

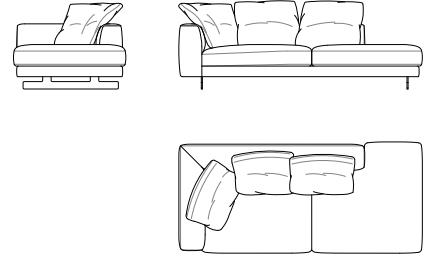

R

L

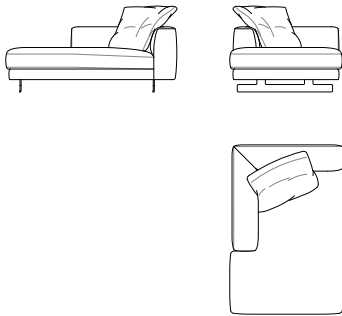

**530 - 520**

L 105 x P 160 x H 82 cm

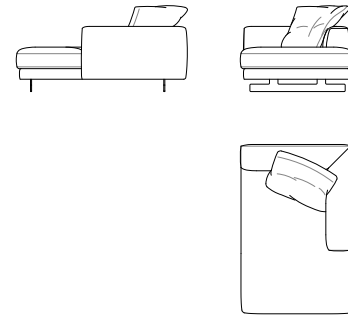

R

**400**

L 106 x P 106 x H 42 cm

